

PREFERRED SLOPE SHOWN.
CHANGE SLOPE AS NEEDED TO
MATCH ADJACENT EXIST FENCE.

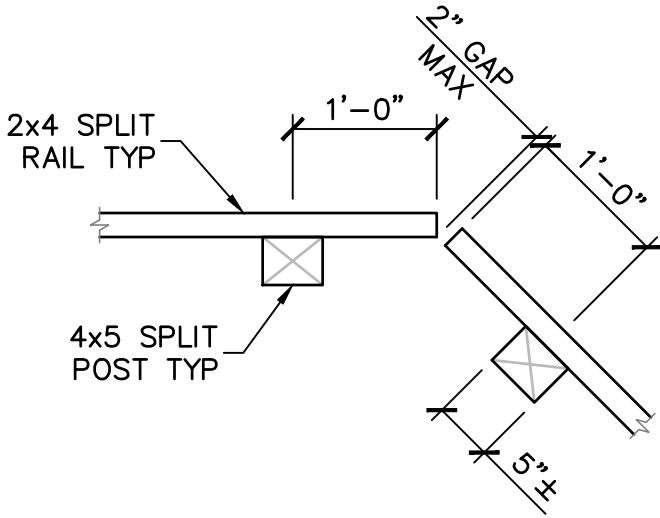

(C) PLAN AT CORNER

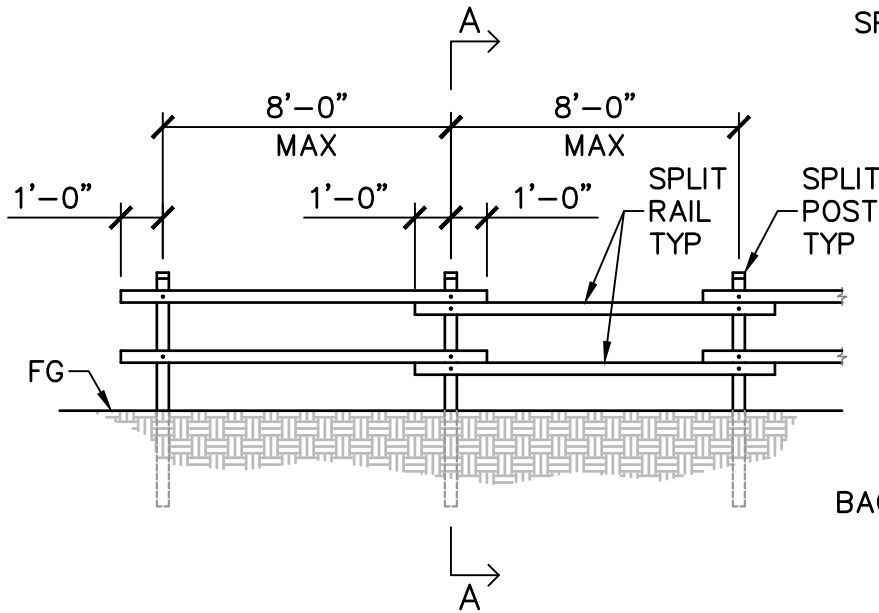

(A) ELEVATION

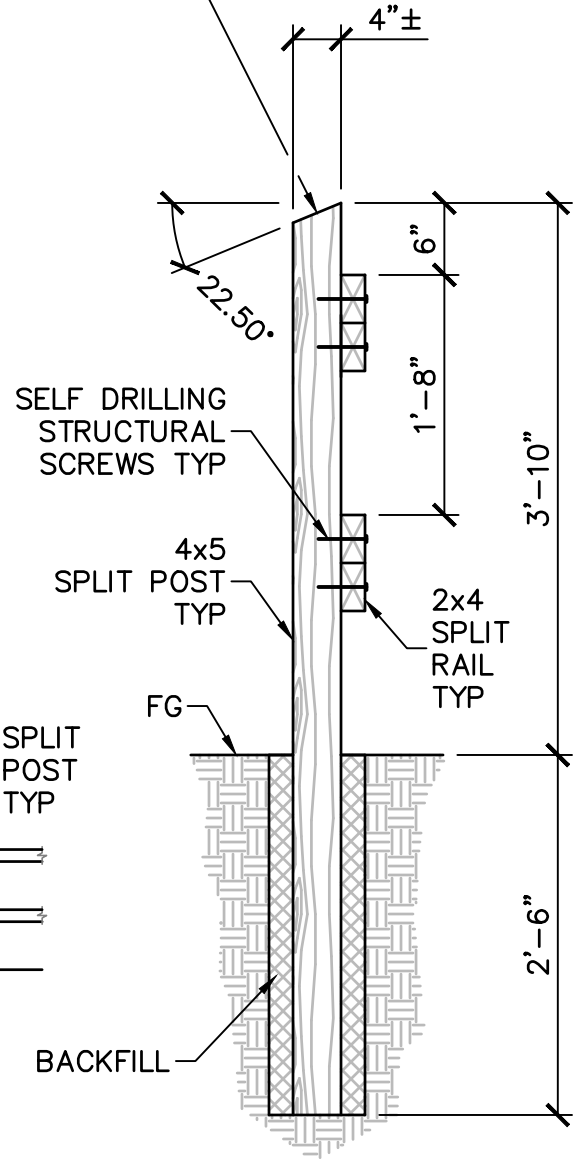

(B) SECTION A-A

SEE NOTES ON SHEET 2



SPLIT RAIL WOOD FENCE

REVIEWED BY THE PARK STANDARDS COMMITTEE, AND APPROVED BY THE CHIEF OF DESIGN & CONSTRUCTION

Signature

11/19/2021

STD PLAN

208

SHEET 1 OF 2
NOT TO SCALE

MATERIALS

1. POSTS AND RAILS SHALL BE SPLIT CEDAR OR FOREST STEWARDSHIP COUNCIL (FSC) CERTIFIED REDWOOD. POSTS AND RAILS SHALL BE OF THE SAME MATERIAL.
2. POSTS SHALL BE 4x5 SPLIT, 78–80 INCHES LONG, WITHOUT MORTISE, THICKNESS MAY VARY.
3. RAILS SHALL BE 2x4 SPLIT, 10FT LONG, WITHOUT TENON OR SCARF ON ENDS, THICKNESS MAY VARY.
4. STRUCTURAL SCREWS SHALL BE ¼” MIN NOMINAL DIA x 4” MIN LENGTH, INTERNATIONAL CODE COUNCIL EVALUATION SERVICE (ICC–ES) APPROVED FOR OUTDOOR USE IN PRESSURE TREATED WOOD, WITH A LOW PROFILE LARGE DIAMETER HEAD NOT REQUIRING A WASHER. USE RSS RUGGED STRUCTURAL SCREW MANUFACTURED BY GRK FASTENERS (WWW.GRKFASTENERS.COM), LOK SERIES BY FASTENMASTER (WWW.FASTENMASTER.COM), STRONG–DRIVE SDWS TIMBER SS SCREW BY SIMPSON STRONG–TIE (WWW.STRONGTIE.COM), OR EQUAL. SCREW HEADS SHALL BE INSTALLED FLUSH OR SLIGHTLY COUNTERSUNK PER MFG.

WORKMANSHIP

5. LOCATE UNDERGROUND UTILITIES PRIOR TO DIGGING. CALL USA (UNDERGROUND SERVICE ALERT) 1–800–277–2600, MON THRU FRI 6AM TO 7PM, A MINIMUM 2 WORKING DAYS WITH A MAXIMUM 14 CALENDAR DAYS, TO OBTAIN A TICKET. CONTACT THE DISTRICT INSPECTOR OR PARK SUPERVISOR FOR DISTRICT UTILITIES NOT LOCATED BY USA.
6. SET POSTS PLUMB AND BACKFILL WITH NATIVE MATERIAL. REMOVE ALL ROCKS AND CLODS GREATER THAN 1½” THEN COMPACT IN 6” LIFTS.
7. INSTALL RAILS PARALLEL TO GROUND AND FOLLOW STAGGERED PATTERN AS SHOWN IN THE ELEVATION ON SHEET 1.
8. INSTALL FENCE RAILS FACING THE MOST VISIBLE SIDE OF PARK FACILITIES; FOR EXAMPLE, FENCES ALONG TRAILS SHALL HAVE THE RAILS FACING THE TRAIL, FENCES AT PARK ENTRIES SHALL HAVE RAILS FACING THE ENTRY ROAD, AND FENCES AROUND PARKING AREAS SHALL HAVE RAILS FACING THE INSIDE OF THE PARKING AREA, UNLESS OTHERWISE NOTED.
9. INSTALL STRUCTURAL SCREWS CENTERED ON AND PERPENDICULAR TO MEMBERS WITH AN EVEN AND EQUIDISTANT PATTERN.
10. SPLIT RAIL POSTS AND RAILS SHALL NOT BE COATED (DO NOT SEAL, PAINT OR STAIN).



SPLIT RAIL WOOD FENCE

REVIEWED BY THE PARK STANDARDS COMMITTEE, AND APPROVED BY THE CHIEF OF DESIGN & CONSTRUCTION

11/19/2021

STD PLAN

208

SHEET **2** OF **2**
NOT TO SCALE

EAST BAY REGIONAL PARK DISTRICT - STANDARD PLANS